

ATTENZIONE: PER TENSIONI SPECIALI, SPECIFICARE SEMPRE IL MODELLO DI FORNO ED IL NUMERO DI MATRICOLA
ATTENTION: FOR SPECIAL VOLTAGES, PLEASE ALWAYS SPECIFY THE OVEN MODEL AND THE SERIAL NUMBER

ATTENTION: POUR TENSIONS SPÉCIALES, MERCI DE SPÉCIFIER TOUJOURS LE MODÈLE DU FOUR ET LE NUMÉRO DE SÉRIE
ACHTUNG: BEI SONDRSPANNUNGEN, BITTE IMMER OFEN-MODELL UND SERIENNUMMER GEBEN.

ed. 0614

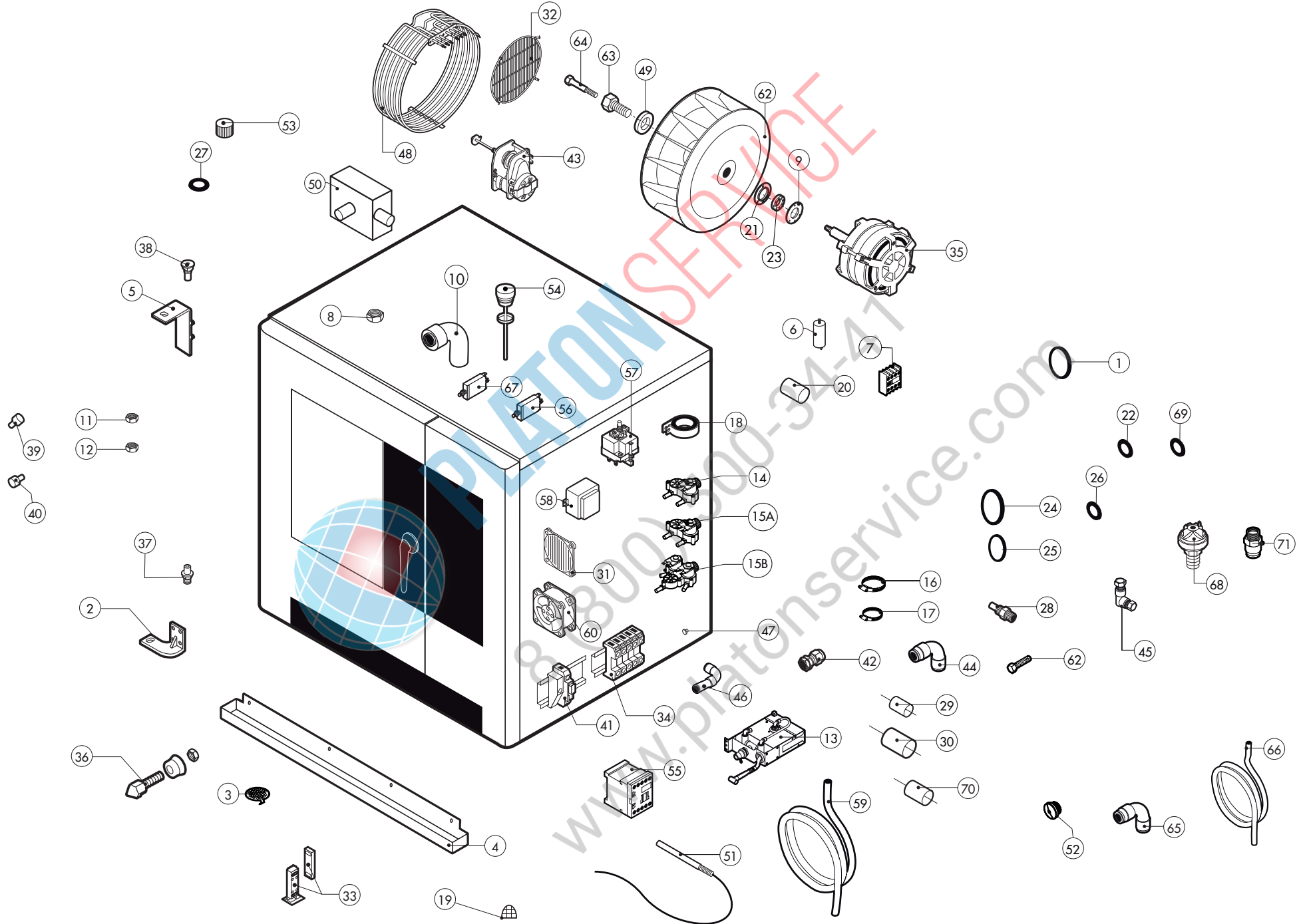

POS.	COD.	Pz.	DESCRIZIONE	DESCRIPTION	DESCRIPTION	BESCHREIBUNG	DESCRIPCIÓN
1	R70010370	2	ANELLO V-SEAL VA-0050 NBR	RING V-SEAL VA-0050 NBR	ANNEAU V-SEAL VA-0050 NBR	RING V-SEAL VA-0050 NBR	ANILLO V-SEAL VA-0050 NBR
2	R11207240	1	ASS.CERNIERA INF. M-V/061-101-102 2005	LOWER DOOR HINGE	CHARNIERE INFERIEURE PORTE	UNTERES SCHARNIER	BISAGRA INFERIOR
3	R10201710	1	ASS.FILTRO DI SCARICO D.86/44.5 M/210-12	DRAIN FILTER	FILTRE ENCEINTE	ABFLUSSFILTER	FILTRO DESAGUE
4	R69180210	1	BACINELLA SCARICO N/S071-101 2014	DRIP TRAY	PLATEAU D'ÉGOUTTEMENT	WASSERTROPFTASSE	BANDEJA DEL GOTEO
5	R14402130	1	CERNIERA SUPERIORE PORTA N/S 2014	UPPER DOOR HINGE	CHARNIERE SUPERIEURE PORTE	OBERES SCHARNIER	BISAGRA SUPERIOR
6	R65190180	1	CONDENS. 10µF V425-B C/CAP. C/COD. 36x58	CAPACITOR	CONDENSATEUR	KONDENSATOR	CONDENSADOR
7	R65140420	1	CONT.AUS. 1L+1R 3RH1911-1FA11 SIEMENS	AUX.CONTACT 1L+1R	CONTACT AUXILIAIRE 1L+1R	ZUSÄTZLICHER KONTAKT 1L+1R	CONTACTO AUXILIAR 1L+1R
8	R65240040	1	CONTRODADO PER RACCORDO 107 Z/29	CABLE GLAND LOCK NUT	CONTRE-ECROU POUR RONDELLE FIXATION	MUTTER	CONTRODADO PASACABLE
9	R58003870	1	CONTROFLANGIA GUARN.PICCOLA	MOTOR GASKET BRASS COUNTER FLANGE	CONTRE-BRIDE JOINT MOTEUR	GEGENFLANSCH F. MOTORDICHTUNG	CONTRABRIDA JUNTA MOTOR
10	R62280038	1	CURVA C/MORSET.HTS-HTSW X TUBO D.50 D.50X	CURVE WITH TERMINAL	COURBE AVEC BORNIER	KURVE MIT KLEMM	CURVA CON REGLETERA
11	R58004050	1	DADO PER PERNO CERNIERA REG. M/106-220	NUT FOR UPPER DOOR HINGE	ECROU CHEVILLE CHARNIERE SUPERIEURE	MUTTER F. OBERES SCHARNIERSTIFT	TUERCA PARA PERNO BISAGRA SUPERIOR
12	R58000360	1	DADO PER PERNO CERNIERA REG. N/S 2014	NUT FOR UPPER DOOR HINGE	ECROU CHEVILLE CHARNIERE SUPERIEURE	MUTTER F. OBERES SCHARNIERSTIFT	TUERCA PARA PERNO BISAGRA SUPERIOR
13	R62200172	1	DOCCIONE AV. N071/101/072/102 2014	SHOWER KIT	KIT DOUCHETTE	HANDBRAUSESATZ	KIT DUCHA
14	R65110230	1	E.V. 2 VIE 1P+1D 220V/50HZ J. G. CON ATTACC FINO ALLA SETTIMANA 10/2015	SOLENOID VALVE 2 VIE 220V 50HZ UNTIL WEEK 10/2015	ELECTROVANNE 2 VIE 220V 50HZ ÉLIMINÉ DU SEMAINE 10/2015	MAGNETVENTIL 2 VIE 220V 50HZ BIS WOCHTE 10/2015	ELECTROVALVULA 2 VIE 220V 50HZ ELIMINATO DEL SEMANA 10/2015
14	R65110340	1	E.V. 2VIE 1PD+1D 230V 50/60HZ OUT J.G. D.10 DALLA SETTIMANA 10/2015	SOLENOID VALVE 1PD+1D 230V 50/60HZ OUT J.G. D.10 SINCE WEEK 10/2015	ELECTROVANNE 1PD+1D 230V 50/60HZ OUT J.G. D.10 DU SEMAINE 10/2015	MAGNETVENTIL 1PD+1D 230V 50/60HZ OUT J.G. D.10 VOM WOCHTE 10/2015	ELECTROVALVULA 1PD+1D 230V 50/60HZ OUT J.G. D.10 DEL SEMANA 10/2015
15A*	R65110230	1	E.V. 2 VIE 1P+1D 220V/50HZ J. G. CON ATTACC FINO ALLA SETTIMANA 10/2015	SOLENOID VALVE 2 VIE 220V 50HZ UNTIL WEEK 10/2015	ELECTROVANNE 2 VIE 220V 50HZ ÉLIMINÉ DU SEMAINE 10/2015	MAGNETVENTIL 2 VIE 220V 50HZ BIS WOCHTE 10/2015	ELECTROVALVULA 2 VIE 220V 50HZ ELIMINATO DEL SEMANA 10/2015
15A*	R65110340	1	E.V. 2VIE 1PD+1D 230V 50/60HZ OUT J.G. D.10 DALLA SETTIMANA 10/2015	SOLENOID VALVE 1PD+1D 230V 50/60HZ OUT J.G. D.10 SINCE WEEK 10/2015	ELECTROVANNE 1PD+1D 230V 50/60HZ OUT J.G. D.10 DU SEMAINE 10/2015	MAGNETVENTIL 1PD+1D 230V 50/60HZ OUT J.G. D.10 VOM WOCHTE 10/2015	ELECTROVALVULA 1PD+1D 230V 50/60HZ OUT J.G. D.10 DEL SEMANA 10/2015
15B**	R65110240	1	E.V. 3 VIE 2P+1D 220V/50HZ J.G.CON ATTACC FINO ALLA SETTIMANA 10/2015	SOLENOID VALVE 3 VIE 220V 50HZ UNTIL WEEK 10/2015	ELECTROVANNE 3 VIE 220V 50HZ ÉLIMINÉ DU SEMAINE 10/2015	MAGNETVENTIL 3 VIE 220V 50HZ BIS WOCHTE 10/2015	ELECTROVALVULA 3 VIE 220V 50HZ ELIMINATO DEL SEMANA 10/2015
15B**	R65110360	1	E.V. 3 VIE 2P+1D 230V 50/60HZ OUT J.G. D10 DALLA SETTIMANA 10/2015	SOLENOID VALVE 3VIE 2P+1D 230V 50/60HZ OUT J.G. D10 SINCE WEEK 10/2015	ELECTROVANNE 3VIE 2P+1D 230V 50/60HZ OUT J.G. D10 DU SEMAINE 10/2015	MAGNETVENTIL 3VIE 2P+1D 230V 50/60HZ OUT J.G. D10 VOM WOCHTE 10/2015	ELECTROVALVULA 3VIE 2P+1D 230V 50/60HZ OUT J.G. D10 DEL SEMANA 10/2015
16	R61630031	4	FASCETTE ZINC.40-60/9	METAL CLAMPS 40-60/9	COLLIER DE SERRAGE 40-60/9	VERZINKTE SCHELLEN 40-60/9	ABRAZADERA 40-60/9
17	R61630011	2	FASCETTE ZINC.12-22/9	METAL CLAMPS	COLLIER DE SERRAGE	VERZINKTE SCHELLEN	ABRAZADERA
18	R65280490	1	FERRITE TOROIDALE FT36	FERRITE FT36	FERRITE FT36	FERRIT FT36	FERRITA FT36
19	R69180250	1	FILTRO SCARICO BACINELLA	SUPPRESSOR	FILTRE	FILTER	FILTRO
20	R65280200	3	FILTRO Cx=0,47µF Cy=2X10nF	INTERFERENCE SUPPRESSOR	FILTRE ANTIPARASITES	STOERSCHUTZFILTER	FILTRO
21	R58003860	1	FLANGIA GUARN. PICCOLA	MOTOR GASKET BRASS FLANGE	BRIDE JOINT MOTEUR	FLANSCH F. MOTORDICHTUNG	BRIDA JUNTA MOTOR
22	R70010030	1	GUARNIZIONE OR 6,07 X 1,78 SILICONE	GASKETS	JOINT	RINGDICHTUNG	JUNTA
23	R70020040	1	GUARNIZIONE MARK IV MLA 1500.02.05	GASKETS	JOINT	RINGDICHTUNG	JUNTA
24	R70010130	1	GUARNIZIONE SILICONE ROSSO 80x50,3x3	RED GASKETS 80x50,3x3	JOINT ROUGE 80x50,3x3	ROTEN DICHTUNG 80x50,3x3	JUNTA ROJA 80x50,3x3
25	R70010150	1	GUARNIZIONE SILICONE ROSSO 55x35x3	RED GASKETS 55x35x3	JOINT ROUGE 55x35x3	ROTEN DICHTUNG 55x35x3	JUNTA ROJA 55x35x3
26	R70010210	1	GUARNIZIONE OR NBR 70 18,72x2,62 C.3075	GASKET OR 18,72x2,62	JOINT OR 18,72x2,62	RINGDICHTUNG OR 18,72x2,62	JUNTA OR 18,72x2,62
27	R70050150	1	GUARNIZIONE X TAPPO 2" PLAST.G40005	GASKETS	JOINT	RINGDICHTUNG	JUNTA
28	R58006160	2	UGELLO COND.D.0,8 CODOLO CIL.10	NOZZLE	BEK	DÜSE	BOQUILLA
29	R70060080	1	MANICOTTO SILICONE D.13X18X80	SILICON SLEEVE	SILICONE SLEEVE	SILIKONHÜLLE	FUNDA DE SILICONA
30	R70060040	2	MANICOTTO SILICONE D.50X50X3	SILICON SLEEVE	SILICONE SLEEVE	SILIKONHÜLLE	FUNDA DE SILICONA
31	R75300020	1	MASCHERINA VENTILATORE D.120 PER VENT.	FAN GUARD GRID D.120	GRILLE VENTILATEUR D.120	VENTILATORSCHUTZGITTER D.120	REJILLA VENTILADOR D.120
32	R75300050	1	MASCHERINA VENTILATORE D.270 N/S071 2014	FAN GUARD GRID D.270	GRILLE VENTILATEUR D.270	VENTILATORSCHUTZGITTER D.270	REJILLA VENTILADOR D.270
33	R65265100	1	MICRO PORTA MAGNETICO COMPLETO	DOOR SWITCH	MICRO PORTE	TUERSCHALTER	MICRO PUERTA

A* - forni senza sistema di lavaggio, oven without washing system, four sans systèmes de lavage, Dämpfer ohne Reinigungssysteme, hornos sin sistema de lavado

B** - forni con sistema di lavaggio, oven with washing system, four avec systèmes de lavage, Dämpfer mit Reinigungssysteme, hornos con sistema de lavado

POS.	COD.	Pz.	DESCRIZIONE	DESCRIPTION	DESCRIPTION	BESCHREIBUNG	DESCRIPCIÓN
34	R65220091	1	MORSETTIERA LX2E (TIPO 2) NEW	TERMINAL BOARD	BORNIER	KLEMMLEISTE	REGLETERA
35	R65040430	1	MOTORE KW 037/005 2-4P 220/2401057	MOTOR	MOTEUR	MOTOR	MOTOR
36	R69010260	1	NASELLO 1 STEP 6303-020022	DOOR LATCH 1 STEP	GACHE DE PORTE POUR OUVERTURE SIMPLE	SCHLIESSNASE 1 STUFE	NARIZ 1 CIERRE
37	R58002670	1	PERNO INF.CERNIERA REG.C./FERMI SR.2005	LOWER HINGE PIN	CHEVILLE CHARNIERE INFERIEURE	UNTERES SIE SCHARNIERSTIFT	PERNO INFERIOR BISAGRA
38	R58000370	1	PERNO SUP.CERNIERA REG. N/S 2014	UPPER HINGE PIN	CHEVILLE CHARNIERE SUPERIEURE	OBERES SIE SCHARNIERSTIFT	PERNO SUPERIOR BISAGRA
39	R58003140	2	PERNO AGGANCIO DEFLETTORE	FAN GUARD PANEL PIN	PIVOT DEFLECTEUR	BOLZEN FÜR LUFTLEITBLECH	PERNO CIERRE DEFLECTOR
40	R58003110	2	PERNO FISSAGGIO DEFLETTORE	FAN GUARD PANEL PIN	PIVOT DEFLECTEUR	BOLZEN FÜR LUFTLEITBLECH	PERNO CIERRE DEFLECTOR
41	R65210020	3	PORTAFUSIBILE BARRA DIN 5x20	FUSE CARRIER	PORTE-FUSIBLE	SICHERUNGSHALTER	PORTAFUSIBILE
42	R65240030	1	PRESSACAVO PG 107 Z/29 (RACCORDO)	FAIRLEAD	PRESSE CABLE	ZUGENTLASTUNG	PRENSACABLES
43	R65090220	1	PROGRAMMAT. 1 CAMME V220/50HZ 1 CIRCUITO	DAMPER SYSTEM	SORTIE EVAPORATION MOUFLE	DAMPFABLASS-STELLMOTOR	MOTOR RESPIRADERO COMPLETO
44	R62090478	4	RACC. INTERMEDIO A GOMITO D.10 PM0310E	ELBOW PIPE FITTING	COURBE AVEC QUEUE	STUCK MIT SCHAFT	RACOR CON CODO
45	R62090633	1	RACCORDO OTTONE CURVO 10/10 C/OGIVA	ELBOW PIPE FITTING BRASS D.10	RACCORDEMENT A COUDE LAITON D 10	WINKELSTUTZEN AUS MESSING D,10	RACOR LATON DE GOMA D.10
46	R62090528	1	RACC.A GOMITO C/CODOLO 10X10 PM221010E	ELBOW PIPE FITTING (WITH TANG) 10 X 10	COURBE AVEC QUEUE 10x10	WINKELVERBINDUNGSSTUCK 10 X 10 MIT SCHAFT	RACOR DE GOMA CON CODO 10x10
47	R65110500	1	REGOL. PORTATA MARRONE ALPHAT. 8lt/h	8 LT/H WATER FLOW REDUCER	REGULATUER DE DEBIT 8 LT.	DURCHFLUSSMONDERER 8L/STD.	REGULADOR DE CAUDAL 8 LT.
48	R65011930	1	RESISTENZA 10000W 230V D8.5 INC. CAM.K 081	CHAMBER HEATING ELEMENT 10000W 230V	RESISTANCE MOUFLE 10000W 230V	GARRAUM HEIZKOERPER 10000W 230V	RESISTENCIA CAMARA 10000W 230V
49	R58004010	1	ROND.FISS.VENTOLA D 30/12.5	FAN WASHER Ø 30/12.5	RONDELLE TURBINE Ø 30/12.5	UNTERLEGSSCHEIBE Ø 30/12.5	ARANDELA FIJACION TURBINA Ø 30/12.5
50	R69180120	1	SCATOLA COND.SCARICO G/MV T06-T10-T21	QUENCHING-DRAIN COLLECTOR	BOITE DE CONDENSATION DECHARGE	KONDENSATION-ABFLUSS SCHACHTEL	CAJÓN CONDENSACION-DESAGÜE
51	R65320220	2	SONDA "K" 6X80 1,5 ML. TESTA RASTREM. 20 mm	PROBE "K" 6X80 1,5ML.	SONDE "K" 6X80 1,5ML.	FUEHLER "K" 6X80 1,5ML.	SONDA "K" 6X80 1,5ML.
52	R65321370	1	TAPPO ASSENZA CONNETTORE S/C SA 2014	COVER	BOUCHON	ABDECKUNG	TAPON
53	R69150100	1	TAPPO FEMMINA G 2" PP+25%FV NERO	COVER	BOUCHON	ABDECKUNG	TAPON
54	R58006690	1	TAPPO SFIATO COMPLETO SERIE 2014	COVER	BOUCHON	ABDECKUNG	TAPON
55	R65140380	7	TELERUTTORE 3RT1016-1AP02	CONTACTOR	CONTACTEUR	SCHUETZ	CONTACTOR
56	R65160300	1	TERMICO T12-211S-0,8A	THERMIC PROTECTION T12-211S-0,8A	PROTECTION THERMIQUE T12-211S-0,8A	MOTORSCHUTZSCHALTER T12-211S-0,8A	TERMICO T12-211S-0,8A
57	R65070350	1	TERMOSTATO SICUR. 360°C -25K 55.32572.8	THERMOSTAT	THERMOSTAT	THERMOSTAT	TERMOSTATO
58	R65180420	2	TRASF.RE 20VA 0-220-240/12V MOD.163.16	TRANSFORMER 20VA	TRANSFORMATEUR 20VA	TRANSFORMATOR 20VA	TRANSFORMADOR 20VA
59	R80150000	0,06 m	TUBO PE 10MMX7 AZZURRO PM950612E	BLUE PIPE	TUBE	LEITUNG	TUBO AZUL
60	R65060050	2	VENTILATORE COMPATTO D.120 4715MS 23T	COMPONENTS VENTILATION MOTOR D.120	MOTEUR DE REFRROIDISSMENT D.120	ABKULUNGS MOTOR D.120	MOTOR DE ENFRIAMIENTO D.120
61	R75400570	1	VENTOLA D.240X80/6 P.D. 50HZ . K_081 T07	FAN	TURBINE	LUEFTERRAD	PALA VENTILADOR
62	R61260152	2	VITE TCB+A2 M 4X10	SCREW TCB+A2 M 4X10	VIS TCB+A2 M 4X10	SCHRAUBE TCB+A2 M 4X10	TORNILLO TCB+A2 M 4X10
63	R58004000	1	VITE FISS.VENTOLA M/12X1.5 SX	FAN SCREW M12x1.5 SX	VIS DE BLOCAGE TURBINE M12x1.5 SX	VENTILATORSCHRAUBE M12x1.5 SX	TORNILLO FIJACION TURBINA M12x1.5 SX
64	R61020562	1	VITE TE A2 M 6X55 UNI 5737.	MOTOR SCREW TE A2 M6x55	VIS DE BLOCAGE MOTEUR TE A2 M6x55	MOTORSCHRAUBE TE A2 M6x55	TORNILLO MOTOR TE A2 M6x55
65	R62090918	1	RACC. INT. A GOMITO D.10 SPEEDFIT PEM0310W DALLA SETTIMANA 28/2014 (07.07.2014)	WHITE ELBOW PIPE FITTING D.10 FROM WEEK 28/2014 (07.07.2014)	COURBE AVEC QUEUE DU SEMAINE 28/2014 (07.07.2014)	STUCK MIT SCHAFT VOM WOCHE 28/2014 (07.07.2014)	RACOR CON CODO DEL SEMANA 28/2014 (07.07.2014)
66	R80150060	0,9m	TUBO PEX-B 10MM DALLA SETTIMANA 28/2014 (07.07.2014)	WHITE PIPE FROM WEEK 28/2014 (07.07.2014)	TUBE DU SEMAINE 28/2014 (07.07.2014)	LEITUNG VON WOCHE 28/2014 (07.07.2014)	TUBO DEL SEMANA 28/2014 (07.07.2014)
67	R65160320	1	TERMICO T12-211S-2A	THERMIC PROTECTION T12-211S-2A	PROTECTION THERMIQUE T12-211S-2A	MOTORSCHUTZSCHALTER T12-211S-0,8A	TERMICO T12-211S-2A
68	R63070050	1	PRESSOSTATO 1/8" 0,5-0,35 BAR PH/91140	WATER SAFETY PRESSURE SWITCH	INT.A PRESSION SEC.-EAU	WASSER-DRUCKWACHTER	PRESOSTATO AQUA
69	R70010050	1	GUARNIZIONE OR 7,60 X 2,62 OR 3030 NB	GASKETS	JOINT	RINGDICHTUNG	JUNTA
70	R62030113	1	MANICOTTO RIDUZ. FF 1/8-1/4 OTTONE	REDUCTION COUPLING	MANCHON REDUCTION	REDUZIERMUFFE	MANGUITO REDUCCION
71	R62090508	2	RACC.TERMIN.DIR.FIL.CON.10X1/4 PM011002E	STRAIGHT THREADED TERMINAL PIPE FITTING	RACCORDEMENT	ENDVERBINDUNGSSTUCK GESCHNITTEN	RACOR

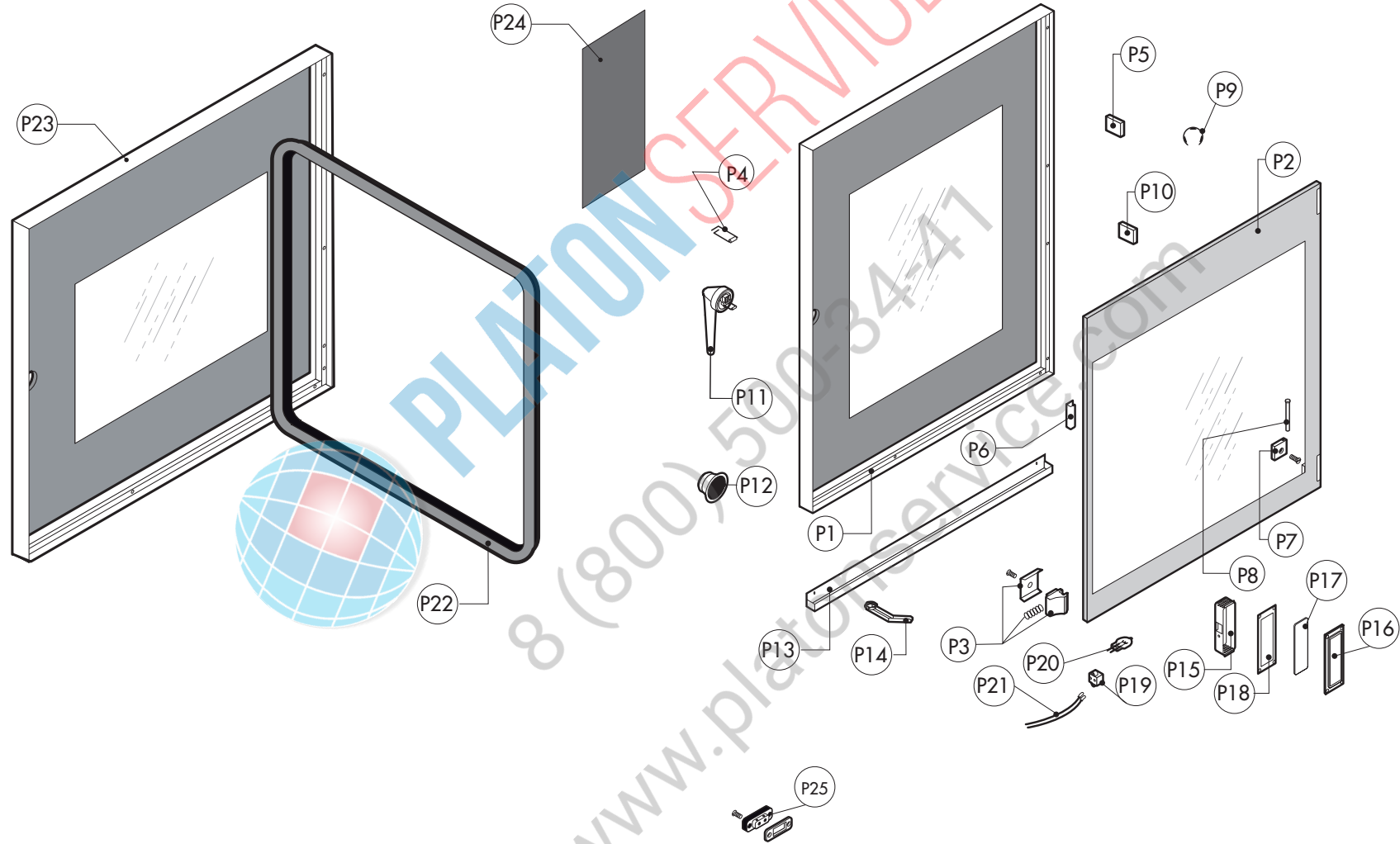

ATTENZIONE: PER TENSIONI SPECIALI, SPECIFICARE SEMPRE IL MODELLO DI FORNO ED IL NUMERO DI MATRICOLA
ATTENTION: FOR SPECIAL VOLTAGES, PLEASE ALWAYS SPECIFY THE OVEN MODEL AND THE SERIAL NUMBER

ATTENTION: POUR TENSIONS SPÉCIALES, MERCI DE SPÉCIFIER TOUJOURS LE MODÈLE DU FOUR ET LE NUMÉRO DE SÉRIE
ACHTUNG: BEI SONDRERSPANNUNGEN, BITTE IMMER OFEN-MODELL UND SERIENNUMMER GEBEN.

ed. 0614

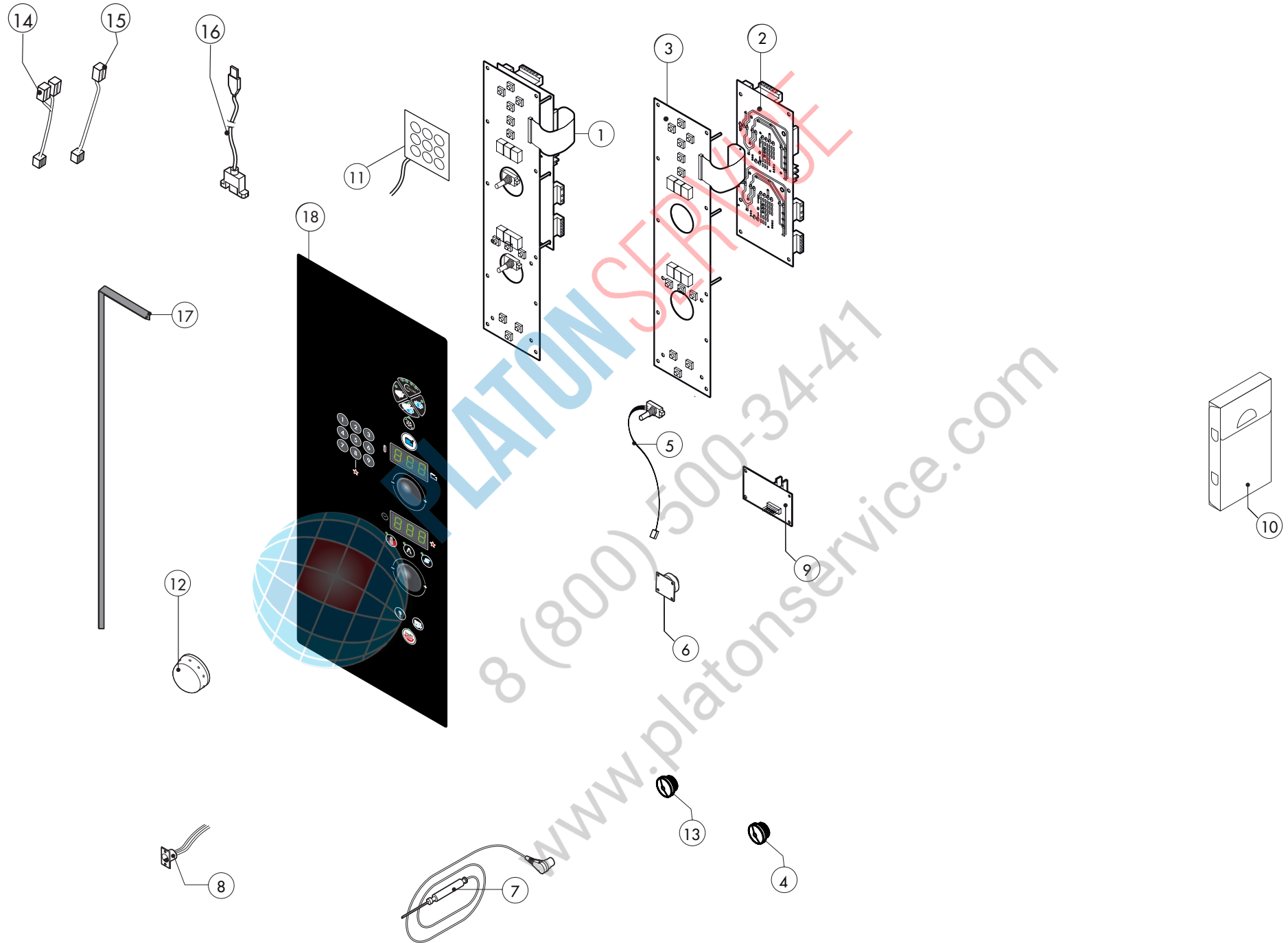

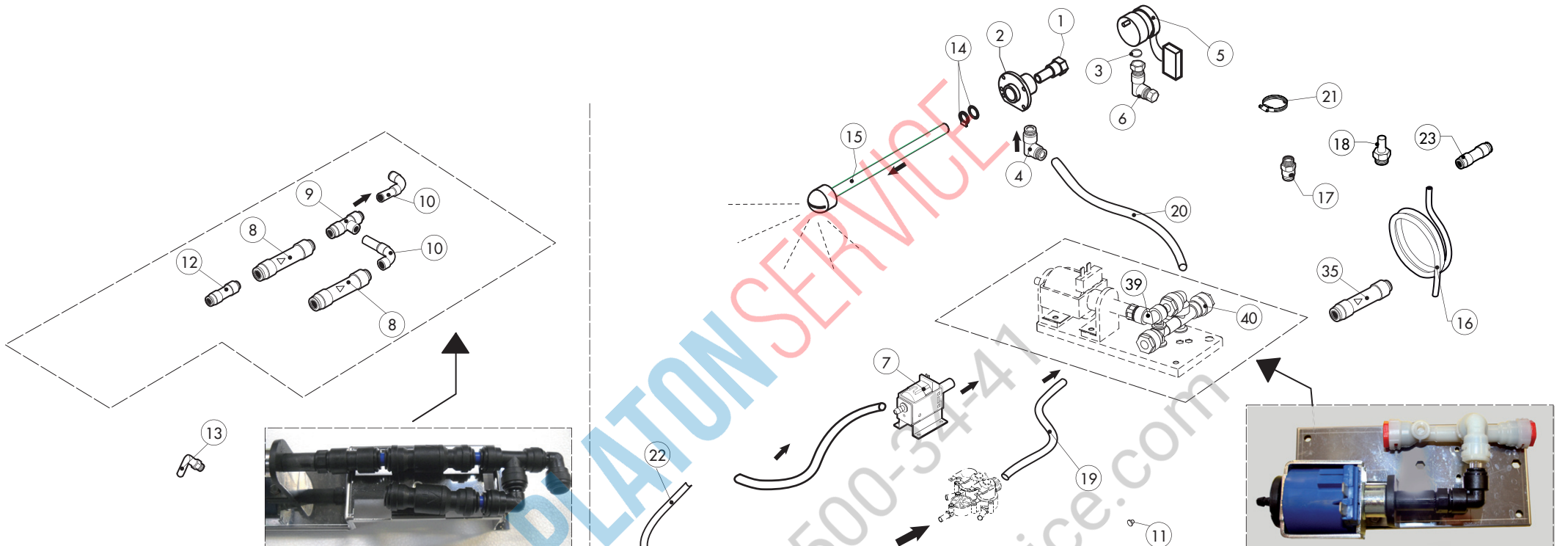

13

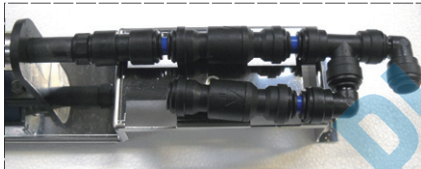

fino alla settimana 27/2014 - until week 27/2014
 élimine du semaine 27/2014
 bis woche 27/2014 - eliminato del semana 27/2014

H₂O

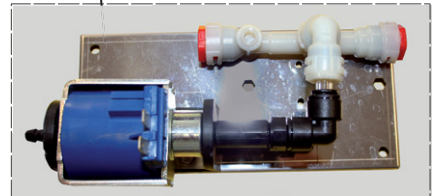

dalla settimana 28/2014 - from week 28/2014
 du semaine 28/2014 - vom woche 28/2014
 del semana 28/2014

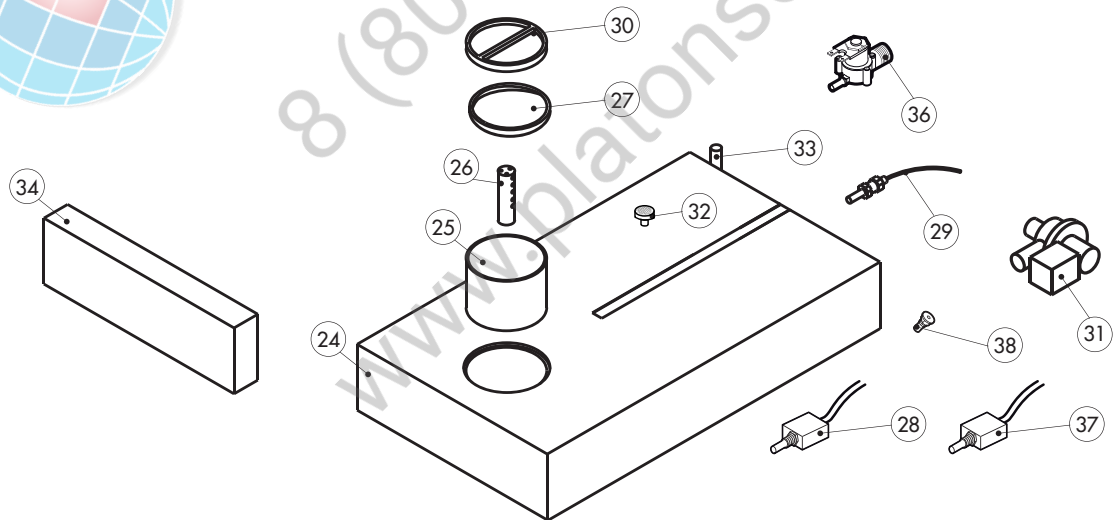

POS.	COD.	Pz.	DESCRIZIONE	DESCRIPTION	DESCRIPTION	BESCHREIBUNG	DESCRIPCIÓN
1	R58007000	1	PERNO ROTANTE LAVAGGIO MOB	ROTATING PIVOT	PIVOT TOURNANT	UMLAUFENDE STÜTZE	GOZNE ROTATORIO
2	R58007020	1	FLANGIA LAVAGGIO MOB	WASHING SYSTEM FLANGE	BRIDE BRAS DE LAVAGE	FLANSCH WASCHARMBEFESTIGUNG	PLATINA LAVADO
3	R70010080	1	GUARNIZIONE OR 14x2 Viton DIN 981	GASKETS	JOINT	RINGDICHTUNG	JUNTA
4	R62090663	1	RACCORDO OTTONE NICH.A L C/OGIVA 10X1/4"	ELBOW PIPE FITTING BRASS D.10x1/4"	RACCORDEMENT A COUDE LAITON D 10x1/4"	ELBOW PIPE FITTING BRASS D.10x1/4"	RACOR LATON DE GOMA D.10x1/4"
5	R65090260	1	MOTORID. LAV. METEOR (58U59DB4A1-00)	WASHING GEARED MOTORS	MOTO-REDUCTEURS DE LAVAGE	GETRIEBEMOTOREN	MOTORREDUCTORES LAVADO
6	R62090633	1	RACCORDO OTTONE CURVO 10/10 C/OGIVA	ELBOW PIPE FITTING BRASS D.10	RACCORDEMENT A COUDE LAITON D 10	WINKELSTUTZEN AUS MESSING D,10	RACOR LATON DE GOMA D.10
7	R65110600	1	POMPA ELETTRIC. A PIS. OSC. ET508LAB 2273	POMPE DETERGEANT	DETERGENT PUMP	REINIGERPUMPE	BOMBA DETERGENTE
8	R65110680	2	VALVOLA ANTIRITORNO J.G. 10SCV Eliminato dalla settimana 27/2014 (4/7/2014)	ANTI-BACK FLOW UNTIL WEEK 27/2014 (4/7/2014)	ANTIRETOUR ÉLIMINÉ DU SEMAINE 27/2014 (4/7/2014)	RUCKFLUSSVERHINDERER BIS WOCH 27/2014 (4/7/2014)	ANTIRETORNO ELIMINATO DEL SEMANA 27/2014 (04/07/2017)
9	R62090468	1	RACCORDO INTERMEDIO A "T" D.10 PM0210E Eliminato dalla settimana 27/2014 (4/7/2014)	T MIDDLING PIPE FITTING D.10 UNTIL WEEK 27/2014 (4/7/2014)	RACCORD INTERMEDIAIRE A "T" D.10 ÉLIMINÉ DU SEMAINE 27/2014 (4/7/2014)	MITTELVERBINDUNGSSTUCK D.10 "T"- FORMIG BIS WOCH 27/2014 (4/7/2014)	RACOR INTERMEDIO TIPO "T" D.10 ELIMINATO DEL SEMANA 27/2014 (04/07/2017)
10	R62090528	1	RACC.A GOMITO C/COD. 10X10 PM221010E Eliminato dalla settimana 27/2014 (4/7/2014)	ELBOW PIPE FITTING (WITH TANG) 10 X 10 UNTIL WEEK 27/2014 (4/7/2014)	COURBE AVEC QUEUE 10x10 ÉLIMINÉ DU SEMAINE 27/2014 (4/7/2014)	WINKELVERBINDUNGSSTUCK 10 X 10 MIT SCHAFT BIS WOCH 27/2014 (4/7/2014)	RACOR DE GOMA CON CODO 10x10 ELIMINATO DEL SEMANA 27/2014 (04/07/2017)
11	R65110530	1	REGOL PORTATA VIOLA 2LT/1'	2 LT/1' WATER FLOW REDUCER	REGULATUER DE DEBIT 2 LT/1'	DURCHFLOSSMONDERER 2 LT/1'	REGULADOR DE CAUDAL 2 LT/1'
12	R62090618	1	RIDUZIONE INTERMEDIA 10-8 PM201008E Eliminato dalla settimana 27/2014 (4/7/2014)	REDUCTION PIPE FITTING UNTIL WEEK 27/2014 (4/7/2014)	RACCORD DROIT REDUCTION ÉLIMINÉ DU SEMAINE 27/2014 (4/7/2014)	GERADE ANSCHLUSS-VERKLEINERUNG BIS WOCH 27/2014 (4/7/2014)	RACOR DERECHO REDUCCION ELIMINATO DEL SEMANA 27/2014 (04/07/2017)
13	R62090678	1	RACC.A GOMITO C/CODOLO 8X8 PM220808E Eliminato dalla settimana 27/2014 (4/7/2014)	ELBOW PIPE FITTING (WITH TANG) 8X8 UNTIL WEEK 27/2014 (4/7/2014)	COURBE AVEC QUEUE 8x8 ÉLIMINÉ DU SEMAINE 27/2014 (4/7/2014)	WINKELVERBINDUNGSSTUCK 8X8 MIT SCHAFT BIS WOCH 27/2014 (4/7/2014)	RACOR DE GOMA CON CODO 8x8 ELIMINATO DEL SEMANA 27/2014 (04/07/2017)
14	R70045120	1	KIT GUARNIZIONI X LAVAGGIO MOB	GASKETS KIT	ENSEMBLE JOINTS	DICHTUNGSSATZ	KIT JUNTAS
15	R58007040	1	TESTA LAVAGGIO MOB+ALBERO L=120 (071/T06)	WASHING SYSTEM INNER ASSEMBLY	ENSEMBLE INTERIEUR DU LAVAGE	INNEN WASCHARMBEFESTIGUNG	KIT INTERNO LAVADO
16	R70070080	1m	TUBO CARICO ACQUA D.23mm x13	PIPE	TUBE	LEITUNG	TUBO
17	R62090508	1	RACC.TERMIN.DIR.FIL.CON.10X1/4 PM011002E	STRAIGHT THREADED TERMINAL PIPE FITTING	RACCORDEMENT	ENDVERBINDUNGSSTUCK GESCHNITTEN	RACOR
18	R62090518	1	RACC.TERMIN.C/COD.F.CON.10X1/4 PM051002E	TERMINAL PIPE FITTING (WITH TANG)	RACCORD AVEC QUEUE	ENDVERBINDUNGSSTUCK MIT SCHAFT	RACOR TERMINAL CON CODO
19	R80120060	1m	TUBO SILIC. TRASP.SR60/TR 7/12.	PIPE	TUBE	LEITUNG	TUBO
20	R80150000	1m	TUBO PE D.10mm x 7 AZZURRO	PE D.10 MM X7 WATER FLEXIBLE PIPE	TUBE FLEXIBLE EAU D. 10x7	WASSERFLEXROHRLEITUNG PE D.10MMX7	TUBO FLEXIBLE AGUA PE D.10mm X 7
21	R61630121	2	FASCETTE ZINC. BIFILARE A MOLLA D.13,7mm	METAL CLAMPS	COLLIER DE SERRAGE	VERZINKTE SCHELLEN	ABRAZADERA
22	R80150020	1,5 m	TUBO PU 8MMX6 TRASPARENTE	PE D.8 MM X 6 DETERGENT FLEXIBLE PIPE	TUBE DETERGEANT D. 8x6	ROHRLEITUNG F. REINIGER PE D.8MMX6	TUBO DETERGENTE PE D.8mm X 6
23	R62090878	1	RACC. INTERMEDIO DIRITTO D.8 PM0408E	PIPE FITTING	COURBE	STUCK	RACOR
24	R14162580	1	CASSETTO DETERGENTE COMPLETO	DETERGENT DRAWER	TIROIR DÉTERGENT	SCHUBFACH REINIGUNGSMITTEL	CAJÓN DETERGENTE
25	R69040060	1	FILTRO CASSETTO MISCELAZIONE N/S 2014	SUPPRESSOR DRAWER	FILTRE TIROIR	FILTER FACH	FILTRO CAJÓN
26	R69040050	1	SPRUZZATORE CASSET. MISCELAZIONE N/S 2014	SPRAY	PULVÉRISER	SPRAY	ROCIAR
27	R69040020	1	GHIERA D.90 CASS. MISCEL.DET. N/S 2014	FERRULE D.90	VIROLE D.90	ZWINGE D.90	CONTERA D.90
28	R65260900	1	MICRO CASSETTO MISCELAZIONE N/S 2014 DALLA SETTIMANA 26/2014 (23/06/2014)	DRAWER MICRO FROM WEEK 26/2014 (23/06/2014)	MICRO TIROIR DU SEMAINE 26/2014 (23/06/2014)	FACH-MICRO VOM WOCH 26/2014 (23/06/2014)	MICRO CAJÓN DEL SEMANA 26/2014 (23/06/2014)
29	R65260910	2	CONTROLLO LIVELLO CASS. MISCEL. N/S 2014	LEVEL CONTROLLER DRAWER	CONTRÔLES DE NIVEAU TIROIR	KONTROLL FACH	CONTROLLOR DE NIVEL CAJÓN
30	R69040040	1	TAPPO D.90 CASS.MISCEL.DET. N/S 2014	COVER	BOUCHON	ABDECKUNG	TAPON
31	R65110300	1	POMPA SINCRONA 220V50HZ30W	POMPE	PUMP	PUMPE	POMPA
32	R62090718	1	FILTRINO D.5 SFIL00VT00	SUPPRESSOR	FILTRE	FILTER	FILTRO
33	R58006960	1	PERNO ø9 DIVIS. CASSETTI N/S 071-101 2014	PIN	PIVOT	BOLZEN	PERNO
34	R69040070	1	FINTO CASSETTO TELAIO N/S 2014	FAKE DRAWER FRAME	CADRE DE TIROIR FAUX	FAKE EINSCHUBRAHMEN	MARCO DE EL CAJÓN FALSO
35	R65110690	1	RACCORDO 3/4F+JG10 C/ANTIRIT. E2120202	PIPE FITTING	COURBÉ	STUCK	RACOR
36	R65110200	1	E.V. 1 VIA 220V 50HZ X J.G. CON ATTACC	SOLENOID VALVE 1 VIE 220V 50HZ	ELECTROVANNE 1 VIE 220V 50HZ	MAGNETVENTIL 1 VIE 220V 50HZ	ELECTROVALVULA 1 VIE 220V 50HZ
37	R65260900K	1	KIT MICROINT. CASSETTO MISC. N/S 2014 eliminato dalla settimana 25/2014 (20/06/2014)	KIT DRAWER MICRO UNTIL WEEK 25/2014 (20/06/2014)	KIT MICRO TIROIR ÉLIMINÉ DU SEMAINE 25/2014 (20/06/2014)	KIT MISCHPLATTE BIS WOCH 25/2014 (20/06/2014)	KIT MICRO CAJÓN ELIMINATO DEL SEMANA 25/2014 (20/06/2014)
38	R58006951	1	PERNO MICRO L=26 C/SEDE MOLLA CAS. DET. N/S DALLA SETTIMANA 26/2014 (23/06/2014)	PIN FROM WEEK 26/2014 (23/06/2014)	PIVOT DU SEMAINE 26/2014 (23/06/2014)	BOLZEN VOM WOCH 26/2014 (23/06/2014)	PERNO DEL SEMANA 26/2014 (23/06/2014)
39	R62090498	1	RACC.INTERMEDIO A GOMITO D.8 PM0308E DALLA SETTIMANA 28/2014 (07/07/2014)	ELBOW PIPE FITTING FROM WEEK 28/2014 (07/07/2014)	COURBE AVEC QUEUE DU SEMAINE 28/2014 (07/07/2014)	WINKELVERBINDUNGSSTUCK VOM WOCH 28/2014 (07/07/2014)	RACOR DE GOMA DEL SEMANA 28/2014 (07/07/2014)
40	R62090888	1	COLLET.RES.ACET. 3VIE- 2D.10+1D.8 + 2ANTI-RIT DALLA SETTIMANA 28/2014 (07/07/2014)	MANIFOLD FROM WEEK 28/2014 (07/07/2014)	COLLECTEUR DU SEMAINE 28/2014 (07/07/2014)	KRÜMMER VOM WOCH 28/2014 (07/07/2014)	COLECTOR DEL SEMANA 28/2014 (07/07/2014)